



NEXCOM International Co., Ltd.

IoT Automation Solutions

Embedded Computing (3.5" CPU Board)

EBC 359

User Manual

CONTENTS

Preface

Copyright	iv
Disclaimer	iv
Acknowledgements	iv
Regulatory Compliance Statements	iv
Declaration of Conformity	iv
RoHS Compliance	v
Warranty and RMA	vi
Safety Information	viii
Installation Recommendations	viii
Safety Precautions	ix
Technical Support and Assistance	x
Conventions Used in this Manual	x
Global Service Contact Information	xi
Package Contents	xiii
Ordering Information	xiv
Barebone	xiv

Chapter 1: Product Introduction

Overview	1
Key Features	1
Hardware Specifications	2
Knowing Your EBC 359	4
Top View	4
Bottom View	5
Rear IO Layout	6
Mechanical Dimensions	7

Chapter 2: Jumpers and Connectors

Before You Begin	6
Precautions	6
Jumper Settings	7
Locations of the Jumpers and Connectors	8
Top View	8
Bottom View	9
Rear I/O Interface	10
LAN Ports	10
Internal I/O Interface	11
Jumper Settings	11
AT/ATX Mode Select	11
GPIO Header 80 Port Select	11
LCD Backlight VCC Power Select	12
COM1 Header Function Select	12
Clear RTC	13
LCD Panel VCC Power Select	13
Internal Connector Pin Definitions	14
Battery Connector	14
CPU Fan Connector	14
Internal DC-in Power Connector	15
Front Panel Audio Header	15
COM1 RS232/422/485 Port Header	16
COM2/3/4/5/6 RS232 Port Header	16
USB 2.0 Port Connector	17
GPIO Port Header	17



- LVDS Inverter Connector 18
- Front Panel Header..... 18
- Dual Channel LVDS/2-Lane EDP Header 19
- SATA 3.0 Port Connector 20
- SATA HDD Power-Out Connector 20
- SM BUS Header..... 21
- 3W Amplifier Connector 21
- Block Diagram 22

Chapter 3: BIOS Setup

- About BIOS Setup 23
- When to Configure the BIOS..... 23
- Default Configuration 24
- Entering Setup 24
- Legends 24
- BIOS Setup Utility..... 26
 - Main 26
 - Advanced..... 26
 - Chipset Menu..... 35
 - Security 36
 - Boot..... 38
 - Save & Exit 38

Appendix A: Maximum Voltage & Current Limit

PREFACE

Copyright

This publication, including all photographs, illustrations and software, is protected under international copyright laws, with all rights reserved. No part of this manual may be reproduced, copied, translated or transmitted in any form or by any means without the prior written consent from NEXCOM International Co., Ltd.

Disclaimer

The information in this document is subject to change without prior notice and does not represent commitment from NEXCOM International Co., Ltd. However, users may update their knowledge of any product in use by constantly checking its manual posted on our website: <http://www.nexcom.com>. NEXCOM shall not be liable for direct, indirect, special, incidental, or consequential damages arising out of the use of any product, nor for any infringements upon the rights of third parties, which may result from such use. Any implied warranties of merchantability or fitness for any particular purpose is also disclaimed.

Acknowledgements

EBC 359 is a trademark of NEXCOM International Co., Ltd. All other product names mentioned herein are registered trademarks of their respective owners.

Regulatory Compliance Statements

This section provides the FCC compliance statement for Class A devices and describes how to keep the system CE compliant.

Declaration of Conformity

FCC

This equipment has been tested and verified to comply with the limits for a Class A digital device, pursuant to Part 15 of FCC Rules. These limits are designed to provide reasonable protection against harmful interference when the equipment is operated in a commercial environment. This equipment generates, uses, and can radiate radio frequency energy and, if not installed and used in accordance with the instructions, may cause harmful interference to radio communications. Operation of this equipment in a residential area (domestic environment) is likely to cause harmful interference, in which case the user will be required to correct the interference (take adequate measures) at their own expense.

CE

The product(s) described in this manual complies with all applicable European Union (CE) directives if it has a CE marking. For computer systems to remain CE compliant, only CE-compliant parts may be used. Maintaining CE compliance also requires proper cable and cabling techniques.

RoHS Compliance



NEXCOM RoHS Environmental Policy and Status Update

NEXCOM is a global citizen for building the digital infrastructure. We are committed to providing green products and services, which are compliant with European Union RoHS (Restriction on Use of Hazardous Substance in Electronic Equipment) directive 2011/65/EU, to be your trusted green partner and to protect our environment.

RoHS restricts the use of Lead (Pb) < 0.1% or 1,000ppm, Mercury (Hg) < 0.1% or 1,000ppm, Cadmium (Cd) < 0.01% or 100ppm, Hexavalent Chromium (Cr6+) < 0.1% or 1,000ppm, Polybrominated biphenyls (PBB) < 0.1% or 1,000ppm, and Polybrominated diphenyl Ethers (PBDE) < 0.1% or 1,000ppm.

In order to meet the RoHS compliant directives, NEXCOM has established an engineering and manufacturing task force in to implement the introduction of green products. The task force will ensure that we follow the standard NEXCOM development procedure and that all the new RoHS components and new manufacturing processes maintain the highest industry quality levels for which NEXCOM are renowned.

The model selection criteria will be based on market demand. Vendors and suppliers will ensure that all designed components will be RoHS compliant.

How to recognize NEXCOM RoHS Products?

For existing products where there are non-RoHS and RoHS versions, the suffix "(LF)" will be added to the compliant product name.

All new product models launched after January 2013 will be RoHS compliant. They will use the usual NEXCOM naming convention.

Warranty and RMA

NEXCOM Warranty Period

NEXCOM manufactures products that are new or equivalent to new in accordance with industry standard. NEXCOM warrants that products will be free from defect in material and workmanship for 2 years, beginning on the date of invoice by NEXCOM. HCP series products (Blade Server) which are manufactured by NEXCOM are covered by a three year warranty period.

NEXCOM Return Merchandise Authorization (RMA)

- Customers shall enclose the “NEXCOM RMA Service Form” with the returned packages.
- Customers must collect all the information about the problems encountered and note anything abnormal or, print out any on-screen messages, and describe the problems on the “NEXCOM RMA Service Form” for the RMA number apply process.
- Customers can send back the faulty products with or without accessories (manuals, cable, etc.) and any components from the card, such as CPU and RAM. If the components were suspected as part of the problems, please note clearly which components are included. Otherwise, NEXCOM is not responsible for the devices/parts.
- Customers are responsible for the safe packaging of defective products, making sure it is durable enough to be resistant against further damage and deterioration during transportation. In case of damages occurred during transportation, the repair is treated as “Out of Warranty.”
- Any products returned by NEXCOM to other locations besides the customers’ site will bear an extra charge and will be billed to the customer.

Repair Service Charges for Out-of-Warranty Products

NEXCOM will charge for out-of-warranty products in two categories, one is basic diagnostic fee and another is component (product) fee.

Repair Service Charges for Out-of-Warranty Products

NEXCOM will charge for out-of-warranty products in two categories, one is basic diagnostic fee and another is component (product) fee.

System Level

- Component fee: NEXCOM will only charge for main components such as SMD chip, BGA chip, etc. Passive components will be repaired for free, ex: resistor, capacitor.
- Items will be replaced with NEXCOM products if the original one cannot be repaired. Ex: motherboard, power supply, etc.
- Replace with 3rd party products if needed.
- If RMA goods can not be repaired, NEXCOM will return it to the customer without any charge.

Board Level

- Component fee: NEXCOM will only charge for main components, such as SMD chip, BGA chip, etc. Passive components will be repaired for free, ex: resistors, capacitors.
- If RMA goods can not be repaired, NEXCOM will return it to the customer without any charge.

Warnings

Read and adhere to all warnings, cautions, and notices in this guide and the documentation supplied with the chassis, power supply, and accessory modules. If the instructions for the chassis and power supply are inconsistent with these instructions or the instructions for accessory modules, contact the supplier to find out how you can ensure that your computer meets safety and regulatory requirements.

Cautions

Electrostatic discharge (ESD) can damage system components. Do the described procedures only at an ESD workstation. If no such station is available, you can provide some ESD protection by wearing an antistatic wrist strap and attaching it to a metal part of the computer chassis.

Safety Information

Before installing and using the device, note the following precautions:

- Read all instructions carefully.
- Do not place the unit on an unstable surface, cart, or stand.
- Follow all warnings and cautions in this manual.
- When replacing parts, ensure that your service technician uses parts specified by the manufacturer.
- Avoid using the system near water, in direct sunlight, or near a heating device.
- The load of the system unit does not solely rely for support from the rackmounts located on the sides. Firm support from the bottom is highly necessary in order to provide balance stability.
- The computer is provided with a battery-powered real-time clock circuit. There is a danger of explosion if battery is incorrectly replaced. Replace only with the same or equivalent type recommended by the manufacturer. Discard used batteries according to the manufacturer's instructions.

Installation Recommendations

Ensure you have a stable, clean working environment. Dust and dirt can get into components and cause a malfunction. Use containers to keep small components separated.

Adequate lighting and proper tools can prevent you from accidentally damaging the internal components. Most of the procedures that follow require only a few simple tools, including the following:

- A Philips screwdriver
- A flat-tipped screwdriver
- A grounding strap
- An anti-static pad

Using your fingers can disconnect most of the connections. It is recommended that you do not use needle-nose pliers to disconnect connections as these can damage the soft metal or plastic parts of the connectors.

Safety Precautions

1. Read these safety instructions carefully.
2. Keep this User Manual for later reference.
3. Disconnect the equipment from any AC outlet before cleaning or installing a component inside the chassis. Use a damp cloth. Do not use liquid or spray detergents for cleaning.
4. To prevent electrostatic build-up, leave the board in its anti-static bag until you are ready to install it.
5. For plug-in equipment, the power outlet socket must be located near the equipment and must be easily accessible.
6. Keep the board away from humidity.
7. Put the board on a stable surface. Dropping it or letting it fall may cause damage.
8. Wear anti-static wrist strap.
9. Do all preparation work on a static-free surface.
10. Make sure the voltage of the power source is correct before connecting the equipment to the power outlet.
11. Hold the board only by its edges. Be careful not to touch any of the components, contacts or connections.
12. All cautions and warnings on the board should be noted.
13. Use the correct mounting screws and do not over tighten the screws.
14. Keep the original packaging and the anti-static bag; in case the board has to be returned for repair or replacement.

Technical Support and Assistance

1. For the most updated information of NEXCOM products, visit NEXCOM's website at www.nexcom.com.
2. For technical issues that require contacting our technical support team or sales representative, please have the following information ready before calling:
 - Product name and serial number
 - Detailed information of the peripheral devices
 - Detailed information of the installed software (operating system, version, application software, etc.)
 - A complete description of the problem
 - The exact wordings of the error messages

Warning!

1. Handling the unit: carry the unit with both hands and handle it with care.
2. Maintenance: to keep the unit clean, use only approved cleaning products or clean with a dry cloth.

Conventions Used in this Manual



Warning:

Information about certain situations, which if not observed, can cause personal injury. This will prevent injury to yourself when performing a task.



Caution:

Information to avoid damaging components or losing data.



Note:

Provides additional information to complete a task easily.

Global Service Contact Information

Headquarters

NEXCOM International Co., Ltd.

9F, No. 920, Zhongzheng Rd.,
Zhonghe District, New Taipei City, 23586,
Taiwan, R.O.C.
Tel: +886-2-8226-7786
Fax: +886-2-8226-7782
www.nexcom.com

Asia

Taiwan

NexAIoT Headquarters

Industry 4.0 and Cloud Services

12F, No.922, Zhongzheng Rd.,
Zhonghe District, New Taipei City,
23586, Taiwan, R.O.C.
Tel: +886-2-8226-7796
Fax: +886-2-8226-7926
Email: sales@nexaiot.com
www.nexaiot.com

NexAIoT Co., Ltd.

Taichung Office

16F, No.250, Sec.2, Chongde Rd.,
Beitun District,
Taichung City, 406, Taiwan, R.O.C.
Tel: +886-4-2249-1179
Fax: +886-4-2249-1172
Email: jacobhuang@nexaiot.com
www.nexaiot.com

NexCOBOT Taiwan Co., Ltd.

13F, No.916, Zhongzheng Rd.,
Zhonghe District,
New Taipei City, 23586, Taiwan, R.O.C.
Tel: +886-2-8226-7786
Fax: +886-2-8226-7926
Email: jennyshern@nexcobot.com
www.nexcobot.com

GreenBase Technology Corp.

13F, No.922, Zhongzheng Rd.,
Zhonghe District,
New Taipei City, 23586, Taiwan, R.O.C.
Tel: +886-2-8226-7786
Fax: +886-2-8226-7900
Email: vivianlin@nexcom.com.tw
www.nexcom.com.tw

DivioTec Inc.

19F-1A, No.97, Sec.4, ChongXin Rd.,
Sanhong District,
New Taipei City, 24161, Taiwan, R.O.C.
Tel: +886-2-8976-3077
Email: sales@diviotec.com
www.diviotec.com

AIoT Cloud Corp.

13F, No.922, Zhongzheng Rd.,
Zhonghe District,
New Taipei City, 23586, Taiwan, R.O.C.
Tel: +886-2-8226-7786
Fax: +886-2-8226-7782
Email: alantsai@aiotcloud.net
www.aiotcloud.dev

EMBUX TECHNOLOGY CO., LTD.

13F, No.916, Zhongzheng Rd.,
Zhonghe District,
New Taipei City, 23586, Taiwan, R.O.C.
Tel: +886-2-8226-7786
Fax: +886-2-8226-7782
Email: info@embux.com
www.embux.com

TMR TECHNOLOGIES CO., LTD.

13F, No.916, Zhongzheng Rd.,
Zhonghe District,
New Taipei City, 23586, Taiwan, R.O.C.
Tel: +886-2-8226-7786
Fax: +886-2-8226-7782
Email: services@tmrtek.com
www.tmrtek.com

China NEXSEC Incorporated

201, Floor 2, Unit 2, Building 15, Yard 3,
Gaolizhang Road, Haidian District,
Beijing, 100094, China
Tel: +86-10-5704-2680
Fax: +86-10-5704-2681
Email: marketing@nexsec.cn
www.nexsec.cn

NEXCOM Shanghai

Room 406-407, Building C, No 154, Lane 953,
Jianchuan Road, Minhang District,
Shanghai, 201108, China
Tel: +86-21-5278-5868
Fax: +86-21-3251-6358
Email: sales@nexcom.cn
www.nexcom.cn

NEXCOM Surveillance Technology Corp.

Floor 8, Building B3, Xiufeng Industrial Zone,
GanKeng Community, Buji Street,
LongGang District,
ShenZhen, 518112, China
Tel: +86-755-8364-7768
Fax: +86-755-8364-7738
Email: steveyang@nexcom.com.tw
www.nexcom.cn

NEXGOL Chongqing

1st Building No.999,
Star Boulevard, Yongchuan Dist,
Chongqing City, 402160, China
Tel: +86-23-4960-9080
Fax: +86-23-4966-5855
Email: sales@nexgol.com.cn
www.nexcom.cn

Beijing NexGemo Technology Co.,Ltd.

Room 205, No.1, Fazhan Rd.,
Beijing International Information Industry Base,
Changping District,
Beijing, 102206, China
Tel: +86-10-8072-2025
Fax: +86-10-8072-2022
Email: sales@nexgemo.cn
www.nexgemo.com

Japan

NEXCOM Japan

9F, Tamachi Hara Bldg.,
4-11-5, Shiba Minato-ku,
Tokyo, 108-0014, Japan
Tel: +81-3-5419-7830
Fax: +81-3-5419-7832
Email: sales@nexcom-jp.com
www.nexcom-jp.com

America

USA NEXCOM USA

46665 Fremont Blvd.,
Fremont CA 94538, USA
Tel: +1-510-656-2248
Fax: +1-510-656-2158
Email: sales@nexcom.com
www.nexcomusa.com

Package Contents

Before continuing, verify that the EBC 359 package that you received is complete. Your package should have all the items listed in the following tables.

Item	Description	Qty
1	EBC 359	1
2	Flat type Heatsink (assembled)	1
3	CPU plate (assembled)	1
4	SATA cable, 50cm	1
5	SATA Power Y cable, 5.0pitch for 32cm, 2.54pitch for 20cm	1
6	COM Port Cable, 22cm, Pitch 2.0	2

Ordering Information

The following below provides ordering information for EBC 359.

Barebone

EBC359 (P/N :6879G0003590F)

3.5" SBC, onboard Intel® Processor N-series, Intel® Processor N97, TDP 12W, 1x DDR5 SO-DIMM, 2 x HDMI, 1 x DP, 1 x LVDS, 1 x USB 3.2 Gen 2, 1 x USB 3.2 Gen 2 Type-C (DP ALT Mode), 8 x USB2.0, 2 x 2.5GbE, 1 x SATA 3.0, 1 x RS232/422/485, 5 x RS232, 3 x M.2

CHAPTER 1: PRODUCT INTRODUCTION

Overview

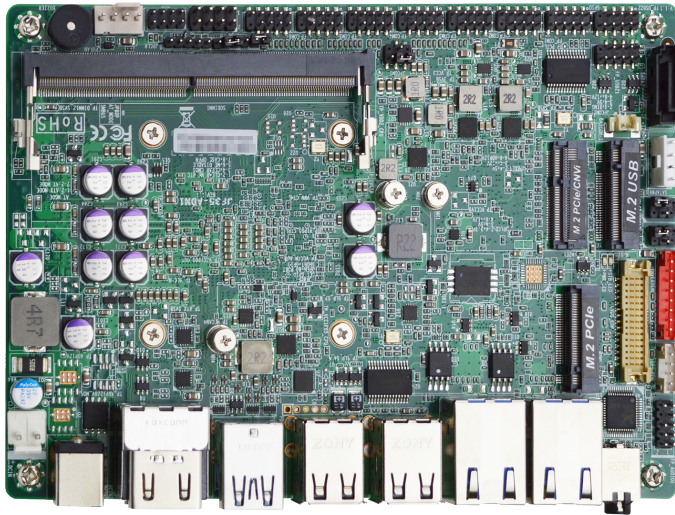

Key Features

- Onboard Intel® Processor, N-Series Processors
- 1 x DDR5 4800MHz SO-DIMM, up to 32GB
- 2 x 2.5GbE LAN port, Intel i225V
- 2 x HDMI 2.0b, 1 x eDP (co-layout LVDS), 1 x LVDS w / Inverter
- 1 x SATA 3.0 (6Gb/s), 6 x COM
- 1 x USB 3.2 Gen 2 Type-A, 8 x USB 2.0, 1 x USB 3.2 Gen 2 Type-C (DP ALT mode)
- 1 x M.2 Key M 2280, supports NVMe
- 1 x M.2 Key E 2230, supports CNVi
- Support 12-28V DC-in

Hardware Specifications

CPU/Chipset

- Onboard Intel® Processor, N-series Processors (formerly Alder Lake N) Intel® Processor N97

Main Memory

- 1 x DDR5 4800MHz SO-DIMM, up to 32GB

BIOS

- UEFI BIOS

Display

- Intel® UHD Graphics
- 1 x LVDS/eDP/MIPI-DSI, 1 x LVDS, up to 1920x1200@60Hz, supports 12V/2A panel (optional eDP)
- 2 x HDMI 2.0b, up to 4096x2160@60Hz
- 1 x DP 1.4a, up to 4096x2304@60Hz (from external USB Type-C)
- Support triple Displays

Ethernet

- 2 x 2.5GbE RJ45 LAN port, Intel i225V

Storage

- 1 x SATA 3.0
- 1 x SATA Power Connector
- 1 x Key M 2280, PCIe 3.0 x2, supports NVMe

Expansion Slot

- 1 x M.2 Key B 3042/3052, USB 3.1 / USB 2.0 interface, supports 4G/5G module
- 1 x M.2 2230 Key E 2230, PCIe x1 / USB 2.0 interface, supports CNVi

Internal I/O

- 4 x USB 2.0
- 1 x RS232/422/485 (COM 1 supports 5V/12V), 5 x RS232
- 1 x LVDS (optional eDP)
- 1 x Audio Header
- 8-Bit GPIO, SMBUS
- 1 x CPU Smart Fan, Nano SIM, HDD LED, PWR LED, POWER button, Reset

Audio

- 1 Audio (Line out / MIC combo)

Watchdog

- 255 Levels

External I/O

- 2 x HDMI 2.0b
- 1 x DP 1.4a (from external USB Type-C)
- 2 x 2.5GbE, supported only with CAT 5e UTP cable
- 1 x USB 3.2 Gen 2 Type-C, DP ALT mode, PD 5V/3A
- 1 x USB 3.2 Gen2 Type-A
- 4 x USB 2.0
- 1 x Audio jack (Line out / MIC combo)
- 1 x 12V-28V DC in jack

Dimensions

- 148mm x 102mm (5.8" x 4")

Power Requirement

- 12~28 V DC-in
- Support both AT and ATX power supply mode

Environment

- Board level operation temperature: -20°C to 60°C
- Storage temperature: -20°C to 85°C
- Relative humidity: 10% to 95% RH (non-condensing)

Certifications

- Meet CE
- FCC Class A

OS Support

- Windows 10 64bit
- Windows 11 64bit

Knowing Your EBC 359

Top View

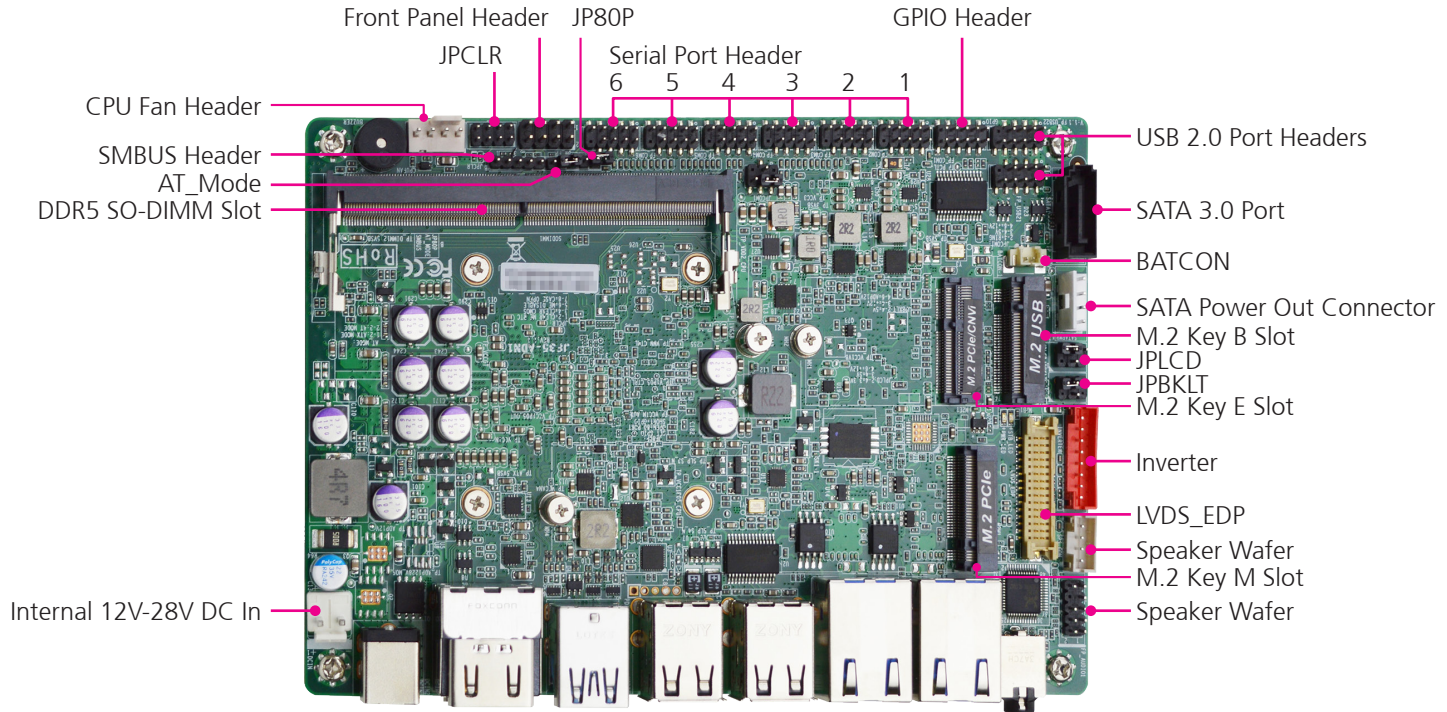

Bottom View

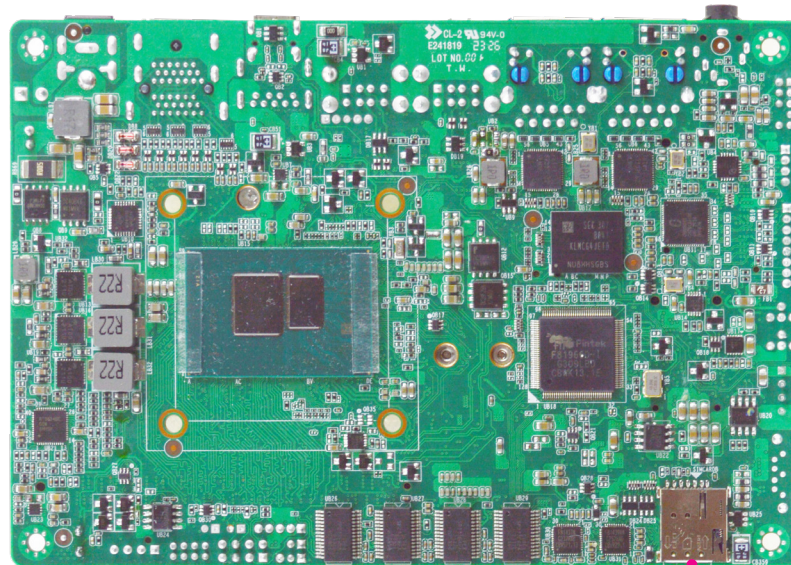

SIM Card Slot

*The SIM card slot operates with the M.2 Key B slot.

Rear IO Layout

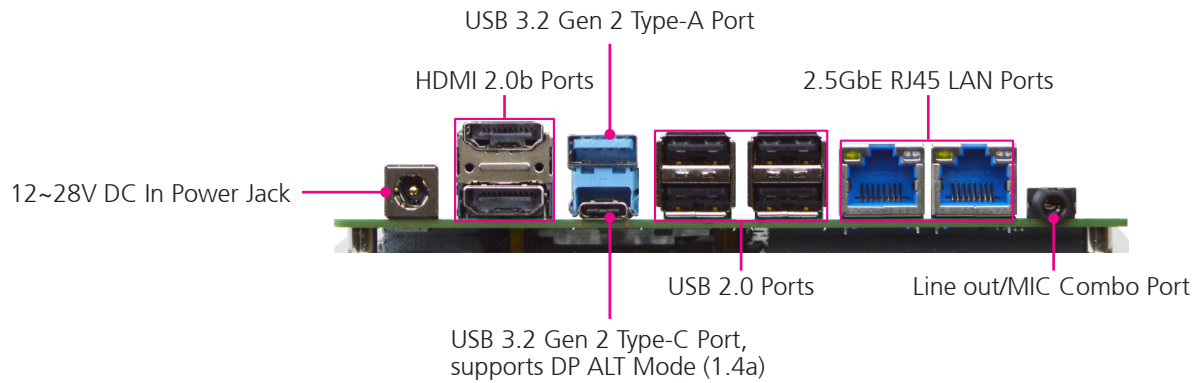

Mechanical Dimensions

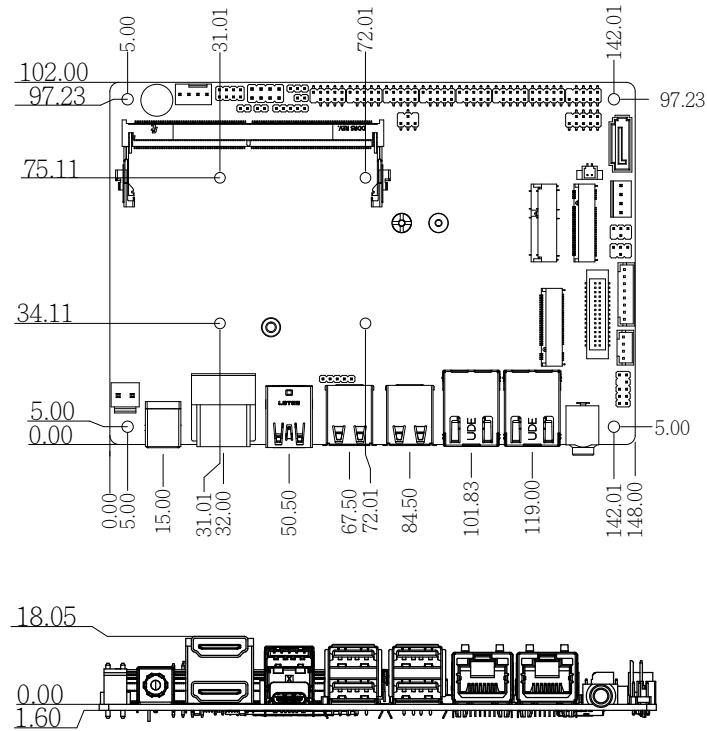

CHAPTER 2: JUMPERS AND CONNECTORS

This chapter describes how to set the jumpers and connectors on the EBC 359 motherboard.

Before You Begin

- Ensure you have a stable, clean working environment. Dust and dirt can get into components and cause a malfunction. Use containers to keep small components separated.
- Adequate lighting and proper tools can prevent you from accidentally damaging the internal components. Most of the procedures that follow require only a few simple tools, including the following:
 - A Philips screwdriver
 - A flat-tipped screwdriver
 - A set of jewelers screwdrivers
 - A grounding strap
 - An anti-static pad
- Using your fingers can disconnect most of the connections. It is recommended that you do not use needle-nosed pliers to disconnect connections as these can damage the soft metal or plastic parts of the connectors.
- Before working on internal components, make sure that the power is off. Ground yourself before touching any internal components, by touching a metal object. Static electricity can damage many of the electronic components. Humid environments tend to have less static electricity than

dry environments. A grounding strap is warranted whenever danger of static electricity exists.

Precautions

Computer components and electronic circuit boards can be damaged by discharges of static electricity. Working on computers that are still connected to a power supply can be extremely dangerous.

Follow the guidelines below to avoid damage to your computer or yourself:

- Always disconnect the unit from the power outlet whenever you are working inside the case.
- If possible, wear a grounded wrist strap when you are working inside the computer case. Alternatively, discharge any static electricity by touching the bare metal chassis of the unit case, or the bare metal body of any other grounded appliance.
- Hold electronic circuit boards by the edges only. Do not touch the components on the board unless it is necessary to do so. Don't flex or stress the circuit board.
- Leave all components inside the static-proof packaging that they shipped with until they are ready for installation.
- Use correct screws and do not over tighten screws.

Jumper Settings

A jumper is the simplest kind of electric switch. It consists of two metal pins and a cap. When setting the jumpers, ensure that the jumper caps are placed on the correct pins. When the jumper cap is placed on both pins, the jumper is short. If you remove the jumper cap, or place the jumper cap on just one pin, the jumper is open.

Refer to the illustrations below for examples of what the 2-pin and 3-pin jumpers look like when they are short (on) and open (off).

Two-Pin Jumpers: Open (Left) and Short (Right)

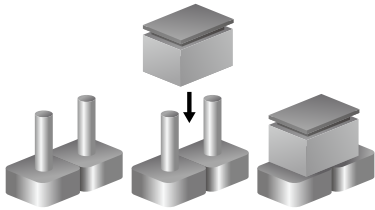

Three-Pin Jumpers: Pins 1 and 2 are Short

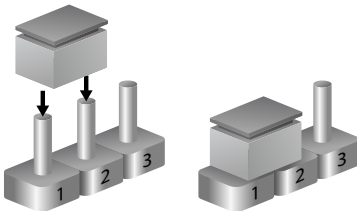

Locations of the Jumpers and Connectors

The figures below show the location of the jumpers and connectors. Refer to this chapter for detailed pin settings and definitions of the connectors marked in pink on the figures.

Top View

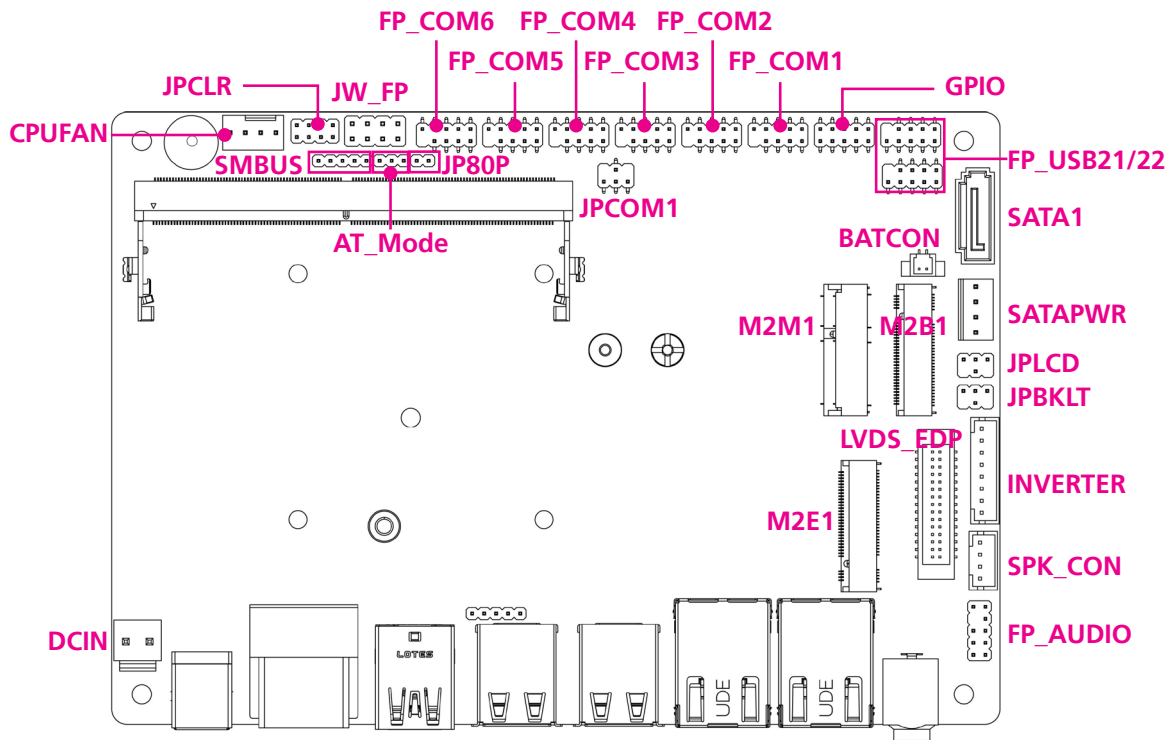

Bottom View

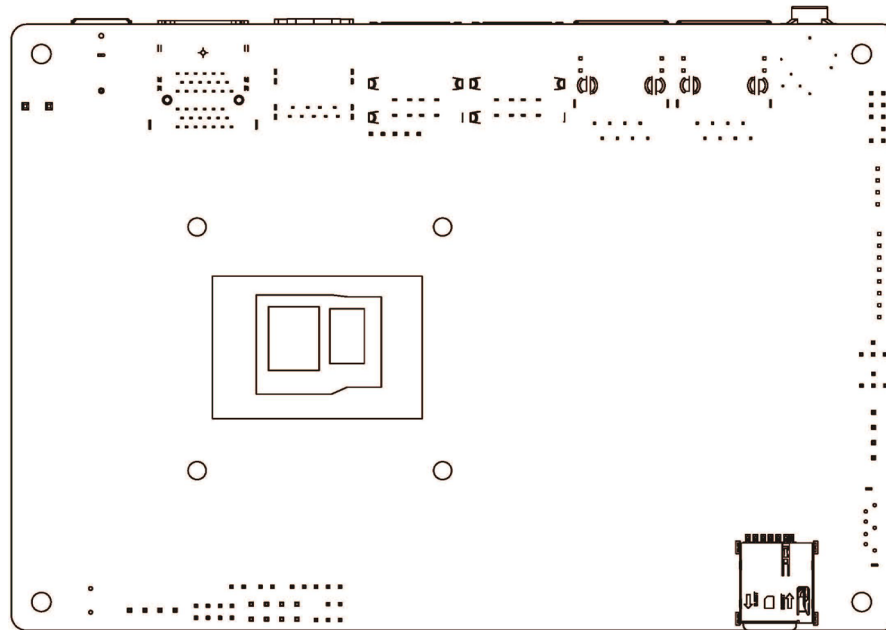

SIM Card Slot

Rear I/O Interface

LAN Ports

Connector type: RJ45 port with LEDs

Connector location: LAN1, LAN2

Act/

Link Speed

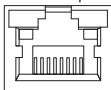

Left: Activity/Link LED		Right: Speed LED	
Status	Description	Status	Description
Off	No Link	Off	10/100 Mbps connection
Blinking	Data Activity	Orange	1000Mbps connection
On	Link	Green	2.5Gbps connection

Internal I/O Interface

Jumper Settings

AT/ATX Mode Select

Connector type: 1x3 3-pin header, 2.0 mm pitch

Connector location: AT_Mode



Pin	Status	Setting
1-2	Closed	ATX Mode (Default)*
2-3	Closed	AT Mode**

*Press power button to power on after power input ready.

**Directly power on as power input ready.

GPIO Header 80 Port Select

Connector type: 1x2 2-pin header, 2.0 mm pitch

Connector location: JP80P



Pin	Status	Setting
1-2	Open	GPIO=80
2-3	Closed	GPIO=GPIO port

LCD Backlight VCC Power Select

Connector type: 1x6 6-pin header, 2.0 mm pitch

Connector location: JPBKLT

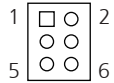

Pin	Status	Setting
2-4	Closed	Backlight Power=5V
3-4	Closed	Backlight Power-12V
4-6	Closed	Backlight Power=Adapter VCC (12)*

*In the case that JPBKLT is set as Pin (4-6) closed, backlight power VCC is the same as adapter buck controller ADP12V.

COM1 Header Function Select

Connector type: 1x6 6-pin header, 2.0 mm pitch

Connector location: JPCOM1

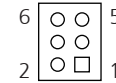

Pin	Status	Setting
2-4	Closed	RI=RING
3-4	Closed	RI=5V
4-6	Closed	RI=12V

Clear RTC

Connector type: 8-pin header, 2.0mm pitch
Connector location: JPCLR

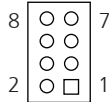

Pin	Status	Setting
1-2	Open	Normal (Default)
1-2	Closed	Clear RTC
3-4	Open	Normal (Default)
3-4	Closed	Clear CMOS*
5-6	Open	Normal (Default)
5-6	Closed	ME Disable
7-8	Open	Normal
7-8	Closed	Case Open**

* Due to Intel MRC Code design, the first reboot after clearing CMOS will perform a full memory sizing, resulting in a boot time of about 40 seconds. This is normal and not indicative of a function failure.

**Pin (7-8) Closed: When the Case Open function pin is shorted to GND, it detects case removal. Users must enable the [Case Open Detect](#) function in BIOS. If the case is removed, a message will appear on screen upon restarting the computer.

LCD Panel VCC Power Select

Connector type: 1x6 6-pin header, 2.0 mm pitch
Connector location: JPLCD

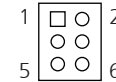

Pin	Status	Setting
2-4	Closed	VCC=3.3V
3-4	Closed	VCC=5V
4-6	Closed	VCC=12V

Internal Connector Pin Definitions

Battery Connector

Connector location: BATCON

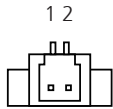

Pin	Definition
1	+
2	-

CPU Fan Connector

Connector location: CPUFAN

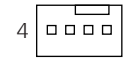

Pin	Definition
1	GND
2	+12V Fan Power
3	Fan Speed
4	Control

Internal DC-in Power Connector

Connector location: DCIN



Pin	Definition
1	+12~28V DC-In
2	GND



The board has a [12V~28V DC-in power connector](#) (DCIN1) on I/O back panel and an internal 12V~28V power connector (DCIN). Users can only connect one type of compatible power supply to one of them to power the system.

Front Panel Audio Header

Connector location: FP_AUDIO

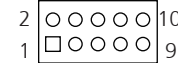

Pin	Definition
1	MIC-L
2	GND
3	MIC-R
4	DETECT
5	LINEOUT2-R
6	MIC-RTU
7	SENSE/NC
8	-
9	LINEOUT2-L
10	LINEOUT2-RTU

COM1 RS232/422/485 Port Header

Connector location: FP_COM1

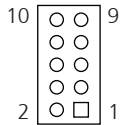

Pin	RS232	RS422	RS485
1	DCD	TX-	DATA-
2	SIN	TX+	DATA+
3	SO-	RX+	NC
4	DTR	RX-	NC
5	GND	GND	GND
6	DSR-	NC	NC
7	RTS-	NC	NC
8	CTS-	NC	NC
9	RI-	NC	NC



FP_COM1 header can function as RS232/422/485 port header. In normal settings, COM1 functions as RS232 header. With compatible COM cable FP_COM1 can function as RS422 or RS 485 header. User also needs to go to BIOS to set [Transmission Mode Select](#) for FP_COM1 at first, before using specialized cable to connect different pins of this port.

COM2/3/4/5/6 RS232 Port Header

Connector location: FP_COM2, FP_COM3, FP_COM4, FP_COM5, FP_COM6

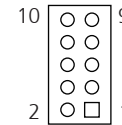

Pin	RS232
1	DCD
2	SIN
3	SO-
4	DTR
5	GND
6	DSR-
7	RTS-
8	CTS-
9	RI-

USB 2.0 Port Connector

Connector location: FP_USB21, FP_USB22

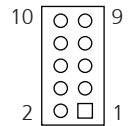

Pin	Definition
1	VCC
2	VCC
3	-DATA
4	-DATA
5	+DATA
6	+DATA
7	GND
8	GND
9	-
10	NC

GPIO Port Header

Connector location: GPIO

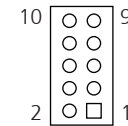

Pin	Definition
1	GPIO80
2	GPIO81
3	GPIO82
4	GPIO83
5	GPIO84
6	GPIO85
7	GPIO86
8	GPIO87
9	GND
10	VCC

LVDS Inverter Connector

Connector location: INVERTER



Pin	Definition
1	Backlight Enable
2	Backlight PWM
3	PVCC
4	PVCC
5	GND
6	GND
7	Backlight Up SW
8	Backlight Down SW

Front Panel Header

Connector location: JP_FP

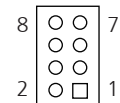

Pin	Definition
1	HDDLED+
2	PWRLED+
3	HDDLED-
4	PWRLED
5	GND
6	FP_SPSW
7	FP_RSTBTN
8	GND

Dual Channel LVDS/2-Lane EDP Header

Connector location: LVDS_EDP

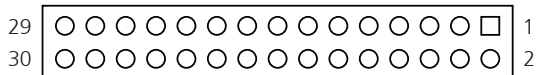

Pin	Definition	Pin	Definition
1	LVDSB_DATAN3	9	LVDSB_DATAN0
2	LVDSB_DATAP3	10	LVDSB_DATAP0
3	LVDSB_CLKN	11	LVDS_DDC_SDA
4	LVDSB-CLKP	12	LVDS_DDC_SCL
5	LVDSB_DATAN2	13	GND
6	LVDSB_DATAP2	14	GND
7	LVDSB_DATAN1	15	GND
8	LVDSB_DATAP1	16	GND

Pin	Definition	Pin	Definition
17	LVDSA_DATAP3	24	LVDSA_DATAN1/eDP_TX1N
18	LVDSA_DATAN3	25	LVDSA_DATAP0
19	LVDSA_CLKP/eDP_AUXP	26	LVDSA_DATAN0
20	LVDSA_CLKN/eDP_AUXN	27	LCD_VCC
21	LVDSA_DATAP2/eDP_TX0P	28	LCD_VCC
22	LVDSA_DATAN2/eDP_TX0N	29	LCD_VCC
23	LVDSA_DATAP1/eDP_TX1P	30	LCD_VCC

SATA 3.0 Port Connector

Connector location: SATA1

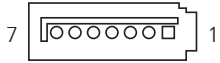

Pin	Definition
1	GND
2	TXP
3	TXN
4	GND
5	RXN
6	RXP
7	GND

SATA HDD Power-Out Connector

Connector location: SATAPWR

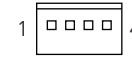

Pin	Definition
1	+5V
2	GND
3	GND
4	+12



Make sure that Pin1 of the compatible SATA Power out connector is inserted into the corresponding Pin1 of SATAPWR connector to avoid possible damage to the board and hard disk drive.

SM BUS Header

Connector location: SMBUS



Pin	Definition
1	SMBUS_CLK
2	SMBUS_DATA
3	SMBUS_ALERT
4	GND
5	VCC3

3W Amplifier Connector

Connector location: SPK_CON

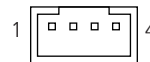

Pin	Definition
1	L-
2	L+
3	R+
4	R-

Block Diagram

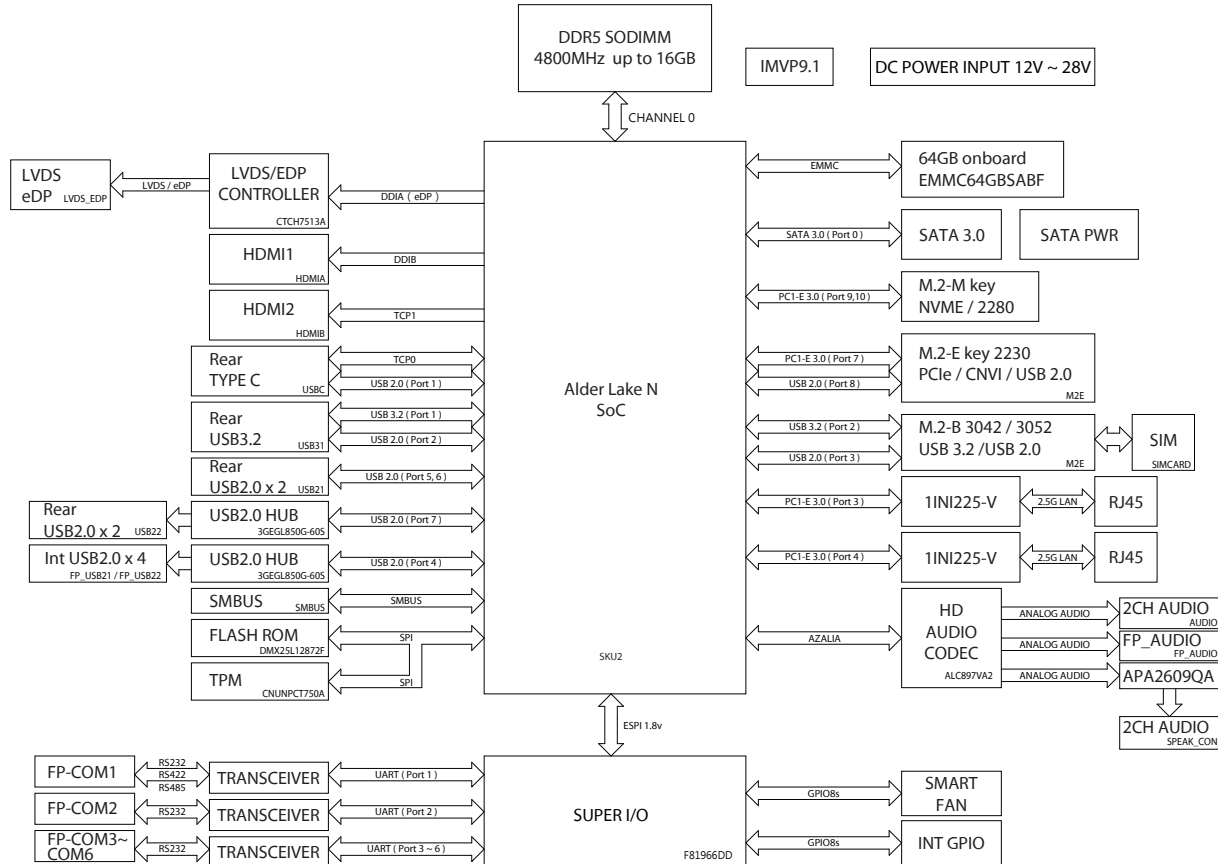

CHAPTER 3: BIOS SETUP

This chapter describes how to use the BIOS setup program for EBC359. The BIOS screens provided in this chapter are for reference only and may change if the BIOS is updated in the future.

To check for the latest updates and revisions, visit the NexCOBOT website at www.nexcobot.com.

About BIOS Setup

The BIOS (Basic Input and Output System) Setup program is a menu driven utility that enables you to make changes to the system configuration and tailor your system to suit your individual work needs. It is a ROM-based configuration utility that displays the system's configuration status and provides you with a tool to set system parameters.

These parameters are stored in non-volatile battery-backed-up CMOS RAM that saves this information even when the power is turned off. When the system is turned back on, the system is configured with the values found in CMOS.

With easy-to-use pull down menus, you can configure such items as:

- Hard drives, diskette drives, and peripherals
- Video display type and display options
- Password protection from unauthorized use
- Power management features

The settings made in the setup program affect how the computer performs. It is important, therefore, first to try to understand all the setup options, and second, to make settings appropriate for the way you use the computer.

When to Configure the BIOS

This program should be executed under the following conditions:

- When changing the system configuration
- When a configuration error is detected by the system and you are prompted to make changes to the setup program
- When resetting the system clock
- When redefining the communication ports to prevent any conflicts
- When making changes to the Power Management configuration
- When changing the password or making other changes to the security setup

Normally, CMOS setup is needed when the system hardware is not consistent with the information contained in the CMOS RAM, whenever the CMOS RAM has lost power, or the system features need to be changed.

Default Configuration

Most of the configuration settings are either predefined according to the Load Optimal Defaults settings which are stored in the BIOS or are automatically detected and configured without requiring any actions. There are a few settings that you may need to change depending on your system configuration.

Entering Setup











When the system is powered on, the BIOS will enter the Power-On Self Test (POST) routines. These routines perform various diagnostic checks; if an error is encountered, the error will be reported in one of two different ways:

- If the error occurs before the display device is initialized, a series of beeps will be transmitted.
- If the error occurs after the display device is initialized, the screen will display the error message.

Powering on the computer and immediately pressing allows you to enter Setup.

Press the  key to enter Setup:

Legends

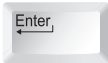
Key	Function
	Moves the highlight left or right to select a menu.
	Moves the highlight up or down between sub-menu or fields.
	Exits the BIOS Setup Utility.
	Scrolls forward through the values or options of the highlighted field.
	Scrolls backward through the values or options of the highlighted field.
	Selects a field.
	Displays General Help.
	Load previous values.
	Load optimized default values.
	Saves and exits the Setup program.
	Press <Enter> to enter the highlighted sub-menu

Scroll Bar

When a scroll bar appears to the right of the setup screen, it indicates that there are more available fields not shown on the screen. Use the up and down arrow keys to scroll through all the available fields.

Submenu

When “▶” appears on the left of a particular field, it indicates that a submenu which contains additional options are available for that field. To display the submenu, move the highlight to that field and press  .

BIOS Setup Utility

Once you enter the AMI BIOS Setup Utility, the Main Menu will appear on the screen. The main menu allows you to select from several setup functions and one exit. Use arrow keys to select among the items and press  to accept or enter the submenu.

Main

The Main menu is the first screen that you will see when you enter the BIOS Setup Utility.

System Date

The date format is <MM/DD/YYYY>. Day displays a day, from Monday to Sunday. Month displays the month, from January to December. Date displays the date, from 1 to 31. Year displays the year, from 2005 to 2099.

System Time

The time format is <HH:MM:SS>. The time is based on the 24-hour military-time clock. For example, 1 p.m. is 13:00:00. Hour displays hours from 00 to 23. Minute displays minutes from 00 to 59. Second displays seconds from 00 to 59.

Advanced

The Advanced menu allows you to configure your system for basic operation. Some entries are defaults required by the system board, while others, if enabled, will improve the performance of your system or let you set some features according to your preference.



Setting incorrect field values may cause the system to malfunction.

CPU Configuration

This section is used to display the current CPU information and configure the installed CPU.

> Efficient-Core Information

Use this item to display the E-Core information

> Performance-Core Information

Use this item to display the P-Core information

> Boot Performance Mode

Use this item to select the performance state that the BIOS will set starting from reset vector.

> Intel® SpeedStep™

Disable or enable to allow more than two frequency ranges to be supported.

> Turbo Mode

Enable or disable processor turbo mode (requires EMTTM enabled too). AUTO means enabled.

> C States

Enable or disable CPU Power Management. It allows CPU to go to C states when it's not 100% utilized.

> Enhanced C-States

Enable or disable C1E. When enabled, CPU will switch to minimum speed when all cores enter C-State.

> Package C State Limit

Configure Maximum Package C State Limit Setting.

Power & Performance

This section is used to configure power and performance control settings.

> CPU-Power Management Control

> CPU-Power Management Control > Power Limit 1 Override

Enable or disable Power Limit 1 override. If this option is disabled, BIOS will program the default values for Power Limit 1 and Power Limit 1 Time Window.

> CPU-Power Management Control > Power Limit 1

Set Power Limit 1 in Milli Watts. BIOS will round to the nearest 1/8W when programming.

0 = no custom override. For 12.50W, enter 12500.

Overclocking SKU: Value must be between maximal and minimal Power Limits (specified by PACKAGE_POWER_SKU_MSR).

Other SKUs: This value must be between Min Power Limit and Processor Base Power (TDP) Limit. If value is 0, BIOS will program Processor Base Power (TDP) value.

> CPU-Power Management Control > Power Limit Time Window

Set Power Limit 1 Time Window value in seconds. The value may vary from 0 to 128. 0 = default value (28 sec for Mobile and 8 sec for Desktop). Defines time window which Processor Base Power (TDP) value should be maintained.

> CPU-Power Management Control > Power Limit 2 Override

Enable or disable Power Limit 1 override. If this option is disabled, BIOS will program the default values for Power Limit 2.

> CPU-Power Management Control > Power Limit 2

Set Power Limit 2 Value in Milli Watts. BIOS will round to the nearest 1/8W when programming. If the value is 0, BIOS will program this value as 1.25* Processor Base Power (TDP). For 12.50W, enter 12500. Processor applies control policies such that the package power does not exceed this limit.

> GT-Power Management Control**> GT-Power Management Control > RC6 (Render Standby)**

Check to enable render standby support.

> GT-Power Management Control > Maximum GT Frequency

Maximum GT frequency limited by the user. Choose between 200MHz (RPN) and 1200MHz (RPO). Value beyond the range will be clipped to min/max supported by SKU.

> GT-Power Management Control > Disable Turbo GT Frequency

Enable or disable Turbo GT frequency.

Trusted Computing

This section is used to configure the settings for the TPM (Trusted Platform Module).

> Security Device Support

Use this item to enable or disable BIOS support for security device. O.S will not show security device. TCG EFI protocol and INT1A interface will not be available. When set as Enabled, users can make the setting in the following items:

> SHA256 PCR Bank

Enable or disable SHA256 PCR Bank.

> SHA384 PCR Bank

Enable or disable SHA384 PCR Bank.

> Pending Operation

Schedule an operation for security device. Your computer will reboot during restart in order to change State of Security Device.

ACPI Settings

This section is used to configure ACPI settings.

> ACPI Sleep State

Select the highest ACPI sleep state the system will enter when the SUSPEND button is pressed.

Super IO Configuration

This section is used to configure Super IO settings.

>Serial Port 1 Configuration

> Serial Port 1 Configuration > Serial Port

Enable or disable serial port 1 (COM 1). When set as Enabled user can make settings in the following items that appear:

> Serial Port 1 Configuration > Change Settings

Select an optimal settings for super IO device.

> Serial Port 1 Configuration > Transmission Mode Select

Select the settings from RS422, RS232, or RS485.

> Serial Port 1 Configuration > Mode Speed Select

Select mode speed.

> Serial Port 2/3/4/5/6 Configuration

> Serial Port 2/3/4/5/6 Configuration > Serial Port

Enable or disable serial port 2/3/4/5/6 (COM 2/3/4/5/6). When set as Enabled user can make settings in the following items that appear:

> Serial Port 2/3/4/5/6 Configuration > Change Settings

Select an optimal settings for super IO device.

> Serial Port 6 Configuration > ERP Support

Configure for energy-related products function. Disable ERP to active all wake-up function.

> Case Open Detect

Detect if case have ever been opened. Show message in POST. When set as Enabled, system will detect if COPEN has been short or not (refer to [JPCLR jumper setting for Case Open Detection](#)); if Pin 7-8 of JPCLR are short, system will show Case Open Message during POST.

> WatchDog Reset Timer

Use this item to support WDT reset function. When set as Enabled, users can make settings in the following items:

> WatchDog Reset Timer Value

Set a value in the range of 10 to 255 seconds or 1 to 255 minutes. WatchDog Reset Timer Unit.

> WatchDog Wake-up Timer

Use this item to support WDT Wake-up. When set as Enabled, users can make settings in the following items that appear:

> WatchDog Wake-up Timer Value

Users can set a value in the range of 10 to 4095 seconds, or 1 to 4095 minutes.

> WatchDog Wake-up Timer Unit

The optional settings are: [Sec.]; [Min.]

> ATX Power Emulate AT Power

This item support Emulate AT power function, MB power On/Off control by power supply. Users needs to select 'AT or ATX Mode' on MB jumper at first (refer to AT MODE jumper setting Pin 1&2 of for ATX Mode & Pin 2&3 of AT Mode Select).

Serial Port Console Redirection

This section is used to configure the serial port that will be used for console redirection.

> COM1**> Console Redirection**

Enable or disable Console Redirection. When set as Enabled, Users can configure more settings in Console Redirection Settings.

> Console Redirection > Console Redirection Settings

Specify how the host computer and the remote computer (which the user is using) will exchange data. Both computers should have the same or compatible settings. More settings are available as follows.

> Console Redirection > Console Redirection Settings > Terminal Type

Select terminal type from the list.

> Console Redirection > Console Redirection Settings > Bits per second

Use this item to select serial port transmission speed. The speed must be matched on the other side. Long or noisy lines may require lower speeds.

> Console Redirection > Console Redirection Settings > Data Bits

Select data bit options.

> Console Redirection > Console Redirection Settings > Parity

Select the parity bit. A parity bit can be sent with the data bits to detect some transmission errors.

> Console Redirection > Console Redirection Settings > Stop Bits

Select the stop bit options. Stop bits indicate the end of a serial data packet.

> Console Redirection > Console Redirection Settings > Flow Control

Flow control can prevent data loss from buffer overflow. When sending data, if the receiving buffers are full, a “stop” signal can be sent to stop the data flow. Once the buffers are empty, a “start” signal can be sent to re-start the flow. Hardware flow control uses two wires to send start/stop signals.

> Console Redirection > Console Redirection Settings > VT-UTF8 Combo Key Support

Enable VT-UTF8 Combination Key Support for ANSI/VT100 terminals.

> Console Redirection > Console Redirection Settings > Recorder Mode

With this mode enabled only text will be sent. This is to capture Terminal data.

> Console Redirection > Console Redirection Settings > Resolution 100x31

Enable or disable extended terminal resolution.

> Console Redirection > Console Redirection Settings > Putty KeyPad

Select FunctionKey and KeyPad on Putty.

> Serial Port for Out-of-Band Management Windows Emergency Management Service (EMS)**> Console Redirection EMS**

Enable or disable console redirection. When set as Enabled, users can make further settings in ‘Console Redirection Settings’ screen.

> Console Redirection EMS > Console Redirection Settings

Specify how the host computer and the remote computer (which the user is using) will exchange data. Both computers should have the same or compatible settings. More setting options are available as follows.

> Console Redirection EMS > Console Redirection Settings > Terminal Type EMS

Select terminal type.

> Console Redirection EMS > Console Redirection Settings**> Bits per second EMS**

Select serial port transmission speed. The speed must be matched on the other side. Long or noisy lines may require lower speeds.

> Console Redirection EMS > Console Redirection Settings > Flow Control EMS

Flow control can prevent data loss from buffer overflow. When sending data, if the receiving buffers are full, a “stop” signal can be sent to stop the data flow. Once the buffers are empty, a “start” signal can be sent to re-start the flow. Hardware flow control uses two wires to send start/stop signals.

> Console Redirection EMS > Console Redirection Settings > Data Bits EMS

Select the data bit option.

*This item may or may not show up, depending on different configuration.

> Console Redirection EMS > Console Redirection Settings**> Parity EMS**

Select the parity bit option.

*This item may or may not show up, depending on different configuration.

> Console Redirection EMS > Console Redirection Settings**> Stop Bits EMS**

Select the stop bit option.

*This item may or may not show up, depending on different configuration.

PC Health Status

This section is to view current hardware health status, and make further settings in **SmartFAN Configuration** and set value in **Shutdown Temperature**.

> SmartFAN Configuration**> SmartFAN Configuration > CPUFAN Smart Mode**

Enable or disable CPUFAN Smart Mode. When set as [Enabled], the following sub-items shall appear:

> SmartFAN Configuration > CPUFAN Full-Speed Temperature

Set CPUFAN full speed temperature. Fan will run at full speed when above this pre-set temperature.

> CPUFAN Smart Mode > CPUFAN Full-Speed Duty

Set CPUFAN full-speed duty. Fan will run at full speed when above this pre-set duty.

> CPUFAN Smart Mode > CPUFAN Idle-Speed Temperature

Set CPUFAN idle speed temperature. Fan will run at idle speed when below this pre-set temperature.

> CPUFAN Smart Mode > CPUFAN Idle-Speed Duty

Set CPUFAN idle speed duty. Fan will run at idle speed when below this pre-set duty.

USB Configuration

This section is to configure USB settings.

> USB Configuration

> XHCI Hand-off

This is a workaround for OSEs without XHCI hand-off support. The XHCI ownership change should be claimed by XHCI driver.

> USB Mass Storage Driver Support

Enable or disable USB Mass storage driver support.

> USB Hardware Delay and Time-out

> USB Transfer time-out

Set the time-out value for control, bulk, and interrupt transfers.

> Device reset time-out

Set the USB mass storage device start unit command time-out.

> Device power-up delay

Set the maximal time the device will take before it properly reports itself to the host controller. 'Auto' uses default value: for a root port it is 100 ms, for a hub port the delay is taken from hub descriptor.

Network Stack Configuration

This section is to configure settings.

> Network Stack

Enable or disable UEFI Network Stack. When set as Enabled, the following sub-items shall appear:

> IPv4 PXE Support

Enable/disable IPv4 PXE Boot Support. When set as Disabled, IPv4 PXE boot support will not be available.

> IPv6 PXE Support

Enable/disable IPv6 PXE Boot Support. When set as Disabled, IPv6 PXE boot support will not be available.

> PXE boot wait time

Wait time in seconds to press [ESC] key to abort the PXE boot. Use either [+] / [-] or numeric keys to set the value.

> Media detect count

Set the number of times presence of media will be checked. Use either [+] / [-] or numeric keys to set the value.

NVMe Configuration

This section is used to configure NVMe Device options settings.

> NVMe Configuration

Enable or disable NVME configuration.

> Wake-up Function Settings

This section is used to configure Wake-up Function Settings.

> Wake-up System With Fixed Time

*This item will only show when 'Wake-up System with Dynamic Time' is set as Disabled. Use this item to enable or disable system wake-up by RTC alarm. When this function is enabled, system will wake on the time (hr::min::sec) specified. When set as Enabled users can make settings in the following items that appear:

> Wake-up Hour

Use this item to select 0-23 for example enter 3 for 3am and 15 for 3pm.

> Wake-up Minute

Use this item to select 0-59.

> Wake-up Second

Use this item to select 0-59.

> Wake-up System with Dynamic Time

*This item will only show when 'Wake-up System with Fixed Time' is set as Disabled. Use this item to enable or disable system wake-up by RTC alarm. When enabled, system will wake on the current time + Increase minute(s) When set as Enabled, users can make settings in the following items that appear:

> Wake-up Minute Increase

Select 1-60 minute(s).

> USB Power Gating S4-S5

USB Wake-up is affected by ERP function in S4. Please disable ERP before activating this function in S4.

> PCIE Wake-up from S3-S5

Enable or disable the PCIE Wakup up S3-S5 function.

PTT Configuration

> PTT Capability/state

> TPM Device Selection

Select TPM device: PTT or dTPM.

PTT- Enables PTT in SkuMgr.

dTPM 1.2 – Disables PTT in SkuMgr.



PTT/dTPM will be disabled and all data saved on it will be lost.

Chipset Menu

System Agent (SA) Configuration

> System Agent (SA) Configuration

> GTT Size

Select GTT Size.

> DVMT Pre-Allocated

Select DVMT 5.0 Pre-Allocated (Fixed) Graphics Memory size used by the Internal Graphics Device.

> Active LFP

Select the Active LFP Configuration. When set as Enabled, the following sub-item shall appear:

> Panel Type

Select panel type from for the device.

> Backlight Control

Select the back light control settings.

> Maximum Memory Frequency

Use this item to set maximum memory frequency selections in MHz.

PCH-IO Configuration

> PCH-IO Configuration

> SATA Configuration

> SATA Configuration > SATA Controller(s)

Enable or disable SATA Device. When set as Enabled, the following sub-items shall appear:

> SATA Configuration > SATA Mode Selection

Determine how SATA controller (s) operate.

> SATA Configuration > Serial ATA Port

> SATA Configuration > Port

Enable or disable SATA Port.

> SATA Configuration > Hot Plug

Designate this port as Hot Pluggable.

> SATA Configuration > HD Audio

Enable or disable HD audio function.

> SATA Configuration > eMMC Controller

Enable or disable SCS eMMC Controller.

> SATA Configuration > System State after Power Failure

Specify what state to go to when power is re-applied after a power failure.

Security

Administrator Password

Select this to configure the administrator's password.

User Password

Select this to configure the user's password.

Secure Boot

> System Mode

> Secure Boot

Secure Boot feature is Active if Secure Boot is enabled, Platform Key (PK) is enrolled and the system is in User mode. The mode change requires platform reset.

> Secure Boot Mode

Secure Boot mode options: Standard or Custom.

In Custom mode, Secure Boot Policy variables can be configured by a physically present user without full authentication.

> Secure Boot Mode > Restore Factory Keys

Force system to User Mode. Install factory default Secure Boot key databases.

> Secure Boot Mode > Reset to Setup Mode

Delete all Secure Boot key databases from NVRAM.

> Secure Boot Mode > Key Management

This item enables expert users to modify Secure Boot Policy variables without variable authentication.

> Secure Boot Mode > Key Management > Vendor Keys**> Secure Boot Mode > Key Management > Factory Key Provision**

Enable or disable to install factory default Secure Boot keys after the platform reset and while the System is in Setup mode.

> Secure Boot Mode > Key Management > Restore Factory Keys

Force System to User Mode. Install factory default Secure Boot key databases.

> Secure Boot Mode > Key Management > Reset to Setup Mode

Delete all Secure Boot key databases from NVRAM.

> Secure Boot Mode > Key Management > Enroll Efi Image

Allow the image to run in Secure Boot mode. Enroll SHA256 Hash certificate of a PE image into Authorized Signature Database (db).

> Secure Boot Mode > Key Management > Export Secure Boot Variables

Save NVRAM content of Secure Boot variables to a file.

> Secure Boot Mode > Key Management > Platform Key(PK) / Key Exchange Keys(KEK) / Authorized Signatures(db) / Forbidden Signatures(dbx) / Authorized TimeStamps(dbt) / OsRecovery Signatures(dbr)

Enroll Factory Defaults or load certificates from a file:

1. Public Key Certificate:

- a) EFI_SIGNATURE_LIST
- b) EFI_CERT_X509 (DER)
- c) EFI_CERT_RSA2048 (bin)
- d) EFI_CERT_SHAXXX

2. Authenticated UEFI Variable

3. EFI PE/COFF Image (SHA256)

Key Source: Factory, Modified, Mixed

Boot

Boot Configuration

Setup Prompt Timeout

Select the number of seconds to wait for the setup activation key. 65535(0xFFFF) denotes indefinite waiting.

Bootup NumLock State

This allows you to determine the default state of the numeric keypad. By default, the system boots up with NumLock on wherein the function of the numeric keypad is the number keys. When set to Off, the function of the numeric keypad is the arrow keys.

Quiet Boot

Enable or disable Quiet Boot option.

Enabled: Displays OEM logo instead of the POST messages.

Disabled: Displays normal POST messages.

Boot Option Priorities

Adjust the boot sequence of the system. Boot Option #1 is the first boot device that the system will boot from, next will be Boot Option #2 and so forth.

Driver Option Priorities

Select driver option sequence of the system.

Save & Exit

Save Changes and Reset

Press Enter to save the changes and reset. Confirm by selecting Yes when a dialogue box appears.

Discard Changes and Reset

Press Enter to exit the BIOS without saving the changes. You may be prompted to confirm again before exiting.

Restore Defaults

Press Enter to restore the BIOS to the default settings. Confirm by selecting Yes when a dialogue box appears.

Save as User Defaults

Press Enter to use the current configurations as user default settings for the BIOS. Confirm by selecting Yes when a dialogue box appears.

Restore User Defaults

Press Enter to restore the BIOS to the user default settings. Confirm by selecting Yes when a dialogue box appears.

Boot Override

Select the desired device and press <Enter> to bypass the boot sequence from the boot option list and boot from a specific device.

APPENDIX A: MAXIMUM VOLTAGE & CURRENT LIMIT

Below is a list of maximum voltage & current limit specification for motherboard interface (including but not limited to slots, connectors, and headers) for setup reference:

	Parts	Current Support	Working Voltage
USB Port from	USBC 1 (Type-C ALT)	5V	3A
	USB31	5V	900mA
	USB21	5V	500mA x 2
	USB22	5V	500mA x 2
	FP_USB21	5V	500mA x 2
	FP_USB22	5V	500mA x 2
	FP_COM1 (JPCOM1)	5V/12V	500mA
	JW_FP	5V	1A
	GPIO	5V	1A
	SMBUS	3.3V	500mA
	LVDS_EDP (JPLCD)	3.3V/5V/12V (via jumper setting)	2A
	INVERTER (JPBKLT)	5V/12V/Adapter 12V (via jumper setting)	2A
	CPUFAN1	12V	1.5A
	SATAPWR	5V	1A